



# ALPHA COMPACT

## 12V AND 24V SERIES

HIGH PERFORMANCE ALTERNATORS



USER AND INSTALLATION MANUAL

[10000014840-02]

## TABLE OF CONTENTS

1	GENERAL INFORMATION .....	3	5.4	Drive belt re-installation .....	12
1.1	Use of this manual .....	3	5.4.1	With auto-tensioner pulley .....	12
1.2	Identification label .....	3	5.4.2	No auto-tensioner pulley .....	12
1.3	Liability .....	3	5.4.3	Final check .....	12
1.4	Warranty .....	3	6	Electrical Installation .....	13
1.5	Disclaimer .....	4	6.1	Precautions .....	13
1.6	Correct Disposal of This Product .....	4	6.2	Fuse .....	13
2	Safety Instructions .....	5	6.3	Wiring .....	13
3	System example .....	6	7	Commissioning .....	15
4	Before you start the installation .....	7	7.1	Preparations .....	15
4.1	Mounting bracket .....	7	7.2	Regulator configuration .....	15
4.2	Sense of rotation .....	7	7.2.1	Set alternator type .....	15
4.3	Isolation bushings .....	7	7.2.2	Other settings .....	15
4.4	Drive belt .....	7	7.3	First operation .....	15
4.5	Engine load .....	7	7.4	Normal operation .....	15
4.6	Pulleys .....	7	8	Maintenance .....	16
4.6.1	Pulley type selection .....	7	8.1	Mounting points .....	16
4.6.2	Pulley size selection .....	8	8.2	Cleaning .....	16
4.6.3	Calculating alternator output .....	8	8.3	Check tension and condition of the drive belt .....	16
4.6.4	Pulley alignment .....	8	9	Troubleshooting .....	17
4.7	Pulley installation .....	9	9.1	Trouble shooting hints .....	17
4.7.1	Standard pulley .....	10	9.2	Fault finding table .....	17
4.7.2	Clutch pulley .....	10	10	Technical Data .....	18
5	Mechanical Installation .....	11	10.1	General specifications .....	18
5.1	Preparations .....	11	10.2	Technical specifications .....	19
5.2	Prepare mounting location .....	11	10.3	Mechanical specifications – Alternators .....	20
5.2.1	Main alternator upgrade .....	11	10.4	Mechanical specifications – Pulleys .....	22
5.2.2	Secondary alternator install .....	11	10.5	Output curves .....	23
5.3	Alternator mounting .....	11			

## 1 GENERAL INFORMATION

### 1.1 Use of this manual

This manual serves as a guideline for the safe and effective operation and maintenance of the following Alpha Compact models:

Product code	Alternator model	Regulator (Alpha Pro III) included	Pulley included
46214120	Alpha Compact 14/120	x	x
46214200	Alpha Compact 14/200	x	✓ (48420110 Pulley Clutch multibelt 6 Ribs 49.8mm)
46228110	Alpha Compact 28/110	x	x
46228150	Alpha Compact 28/150	x	x
46228082	Alpha Compact 28/80 for Volvo Penta	x	✓ (48420170 Pulley Std Multibelt 8 Ribs D=48,1mm)
46228112	Alpha Compact 28/110 for Volvo Penta	x	✓ (48420170 Pulley Std Multibelt 8 Ribs D=48,1mm)
46228152	Alpha Compact 28/150 for Volvo Penta	x	✓ (48420170 Pulley Std Multibelt 8 Ribs D=48,1mm)
46614120	Alpha Compact 14/120	✓	x
46614200	Alpha Compact 14/200	✓	✓ (48420110 Pulley Clutch multibelt 6 Ribs 49.8mm)
46628110	Alpha Compact 28/110	✓	x
46628150	Alpha Compact 28/150	✓	x

Table 1: Overview of models to which this manual refers

These models are further referred to as "Alpha Compact".

### 1.2 Identification label

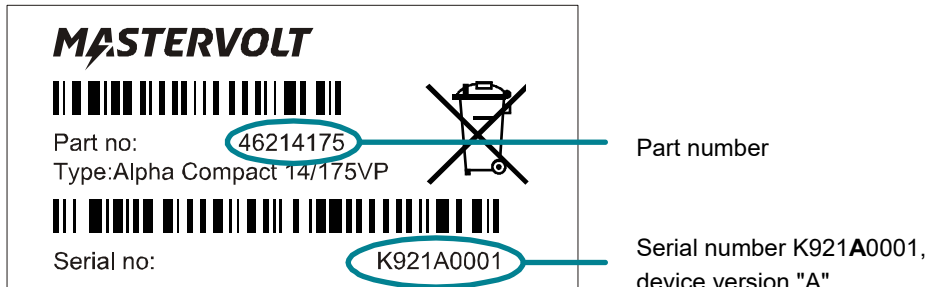


Figure 1: Identification label



#### CAUTION!

Important information required for service or maintenance can be derived from the identification label. Never remove the identification label.

### 1.3 Liability

Mastervolt can accept no liability for:

- Consequential damage resulting from the use of the Alpha Compact.
- Possible errors in the included manual and the consequences of these.
- Use that is inconsistent with the purpose of the product.

### 1.4 Warranty

Mastervolt assures the product warranty of the Alpha Compact during two years after purchase, on the condition that the product is installed and used according to the instructions in this manual.

Installation or use not according to these instructions may result in under performance, damage or failure of the product and may void this warranty. The warranty is limited to the cost of repair and/or replacement of the product. Costs of labor or shipping are not covered by this warranty.

### 1.5 Disclaimer

Our products are subject to continual development and improvement. Therefore, additions or modifications to the products may cause changes to the technical data and functional specifications. No rights can be derived from this document. Please consult our most current Terms & Conditions of Sale.

### 1.6 Correct Disposal of This Product



This product is designed and manufactured with high quality materials and components, which can be recycled and reused. When this crossed-out wheeled bin symbol is attached to a product, it means the product is covered by the European Directive 2012/19/EU.

Please be informed about the local separate collection system for electrical and electronic products.

Please act according to your local rules and do not dispose of your old products with your normal household waste. The correct disposal of your old product will help prevent potential negative consequences to the environment and human health.

## 2 SAFETY INSTRUCTIONS



### **WARNING!**

**Read the entire manual before using the Alpha Compact. Keep this manual in a secure place.**

This chapter describes important safety and operating instructions for use of an Alpha Compact in recreational vehicle (RV) and marine applications.

### **Use the Alpha Compact alternator only:**

- in combination with the Alpha Pro III charge regulator;
- for the charging of lead acid or Li-Ion batteries and the supply of loads connected to these batteries, in permanent systems;
- with fuses, protecting the wiring between alternator/regulator output and battery;
- in a technical correct condition;
- in a closed, well-ventilated area, protected against rain, moist, dust, condensation and (sea)water.

### **Warning regarding life support applications**

Mastervolt products are not designed to be used as component of medical equipment, unless negotiated in the form of a written agreement between customer and/or manufacturer and Mastervolt. Such agreement will require the equipment manufacturer either to contract additional reliability testing of the Mastervolt parts and/or to commit to undertake such testing as a part of the manufacturing process. In addition, the manufacturer must agree to indemnify and not hold Mastervolt responsible for any claims arising from the use of the Mastervolt parts in the life support equipment.

### **Personal precautions**

Remove the keys from the ignition and disconnect all batteries in the system which is being worked on.

During installation or maintenance:

- stick to tools and methods recommended in the manual;
- work in a well ventilated area;
- wear safety glasses and remove loose fitting clothing and jewelry;
- be aware of hot surfaces: both engine parts as well as the alternator.

### **Working procedures**

If the alternator, regulator and engine are switched off during maintenance and/or repair activities, they should be secured against unexpected and unintentional switching on.



### **WARNING!**

**When service has to be carried out while the engine is running, be aware of moving parts like V-belts.**

### 3 SYSTEM EXAMPLE

The following figure shows a typical example of where the Alpha Compact alternator is located in a power system. Please note that this figure is simplified and does not reflect the actual placement of all devices nor the complete connections. For each device, refer to the corresponding installation manual and follow the given instructions.

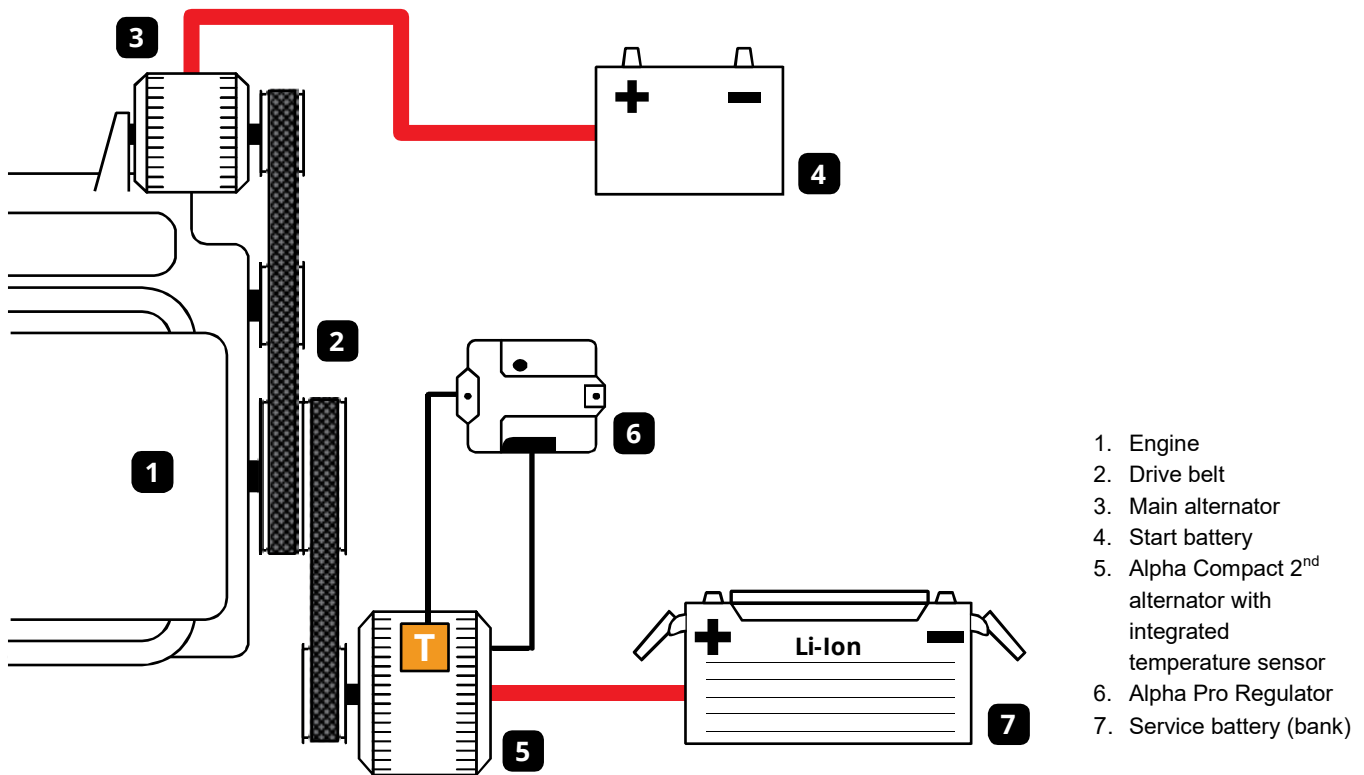


Figure 2. Simplified architecture of a typical dual alternator configuration

#### Alternator

Alpha Compact alternators transform your engine into a high-power energy source for electrical on-board consumers and guarantee a quick charge of your service and starter batteries. Mastervolt alternators are built to operate continuously under the high temperatures of an engine room and can be used either as an upgrade to the main alternator or as a secondary alternator.

#### Accessories

6-ribs and 8-ribs pulleys are available from Mastervolt in both standard and clutch versions. Other available accessories include isolating bushings, an oil pressure switch and B+ adapter for M10 cable lugs. For an up-to-date overview, refer to [www.mastervolt.com](http://www.mastervolt.com).

#### Alpha Pro regulator

The Alpha Compact is designed for use in conjunction with the Alpha Pro III charge regulator, which controls the alternator's output voltage. The Alpha Pro regulator is capable of fast and safe charging of lead-acid and Li-Ion batteries, following the Mastervolt 3-Step charge process.

**Note:** This manual should be read in combination with the Alpha Pro III manual.

## 4 BEFORE YOU START THE INSTALLATION

### 4.1 Mounting bracket

To add a secondary alternator you need a solid mounting bracket which must be resistant to strong vibrations. There are various possibilities:

1. Order the engine with pre-installed alternator bracket (also known as PTO or Generator option).
2. Consult your dealer/distributor for the availability of an aftermarket 2<sup>nd</sup> alternator mounting kit.
3. Construct your own bracket. This is specialist work and should be carried out by qualified personnel only.

Check the instructions, dimensions and specifications included with the alternator bracket or kit to decide which Alpha Compact model best fits your engine.

### 4.2 Sense of rotation

When selecting the installation location, you must take into account the sense of rotation. For the internal fans to work properly, the sense of rotation should be clockwise, viewed from the pulley side of the Alpha Compact.

### 4.3 Isolation bushings

Alpha Compact alternators are non-isolated, meaning the negative output is connected to the metal enclosure. Engine manufacturers may stipulate isolated mounting of the alternator, e.g. to protect sensitive engine electronics. Mastervolt can provide optional isolating bushings suitable for this purpose. For each mounting hole of the alternator, order one set of isolating bushings. See also Figure 4 on page 11.

**Note:** The mounting hole diameters may vary in size, even within a single model. Make sure to order the correct bushing by looking up the mounting hole diameters in section 10.3.

### 4.4 Drive belt

Alpha Compact alternators must be combined with multigroove pulleys and corresponding multirib belt (also known as multibelt or serpentine belt) with profile "PK"; further referred to as "drive belt" or "belt" for short. The drive belt must be capable of driving the total mechanical load of all power consumers on the belt, including the alternator. Please note that Mastervolt does not supply the drive belt.

### 4.5 Engine load

Alpha Compact alternators draw a certain amount of power from the engine. The drive belt and pulley add mechanical losses. As a rule of thumb, the total mechanical-to-electrical power conversion efficiency can be assumed as 50%. Check if the engine has sufficient power reserve to produce the additional power drawn at nominal alternator rpm (refer to Table 2.)

Alpha Compact model	Power Take-Off (kW)
Alpha Compact 14/120	3.4
Alpha Compact 14/200	5.6
Alpha Compact 28/80 VP	4.8
Alpha Compact 28/110 (also VP)	6.2
Alpha Compact 28/150 (also VP)	8.4

Table 2. Indication of the mechanical power taken from the engine at nominal alternator output

### 4.6 Pulleys

For most Alpha Compact models, the pulley must be ordered separately. Mastervolt provides 6-rib and 8-rib pulleys in various diameters and with or without clutch (also called "overrunning" or "freewheeling" pulleys).

**Note:** The Alpha Compact 14/200 and all VP models are standard fitted with a pulley. (For mechanical specifications, see section 10.4 on page 22.)

#### 4.6.1 Pulley type selection

The standard pulley is recommended for most situations. In case of a long drive belt and/or if many power consumers are attached to the belt, the use of a clutch pulley is recommended. This will minimize wear and tear of the belt and belt tensioner.

#### 4.6.2 Pulley size selection

To choose the correct size of the alternator pulley, you must take into account many variables:

- engine size (kW);
- engine idle speed;
- engine cut-off point (= max. rpm);
- alternator maximum rpm;
- diameter of the crank shaft pulley which will be used to drive the alternator.

#### General rules

- At engine idle speed A, the alternator speed B should be 1800rpm or higher (  $B / A$  = minimum pulley ratio).
- At the engine cut-off point D, the alternator speed E should be below the maximum alternator speed (  $E / D$  = maximum pulley ratio).
- Choose a pulley ratio within these extremes.

#### Example

Assumptions: Engine idle speed = 800rpm, Engine cut-off point = 5000rpm, crank shaft pulley diameter = 160 mm. Alternator: Alpha Compact 28/110 (refer to section 10.2 for specifications):

Engine idle speed	A	800	rpm
Alternator idle speed	B	1800	rpm
Minimum pulley ratio (= B / A)	C	2.25	x
Engine max rpm	D	5000	rpm
Alternator maximum speed	E	15000	rpm
Maximum pulley ratio (= E / D)	F	3.0	x
Crank shaft pulley diameter	G	160	mm
Max. alternator pulley diam. (= G / C)	H	71.1	mm
Min. alternator pulley diam. (= G / F)	I	53.3	mm
Selected pulley diameter	J	55	mm
Actual Pulley ratio (= G / J)	K	2.9	x

It follows that the pulley diameter must be in the range of 53.3mm to 71.1mm. Selecting a relatively small diameter has the advantage of high output power at idle and full power reached at low rpm. Selecting a small pulley also means the alternator represents a higher mechanical load to the engine at idle speed. For a powerful engine, you may select a 55mm pulley. For a smaller engine, a larger diameter such as 66mm may be optimal.

#### 4.6.3 Calculating alternator output

Once the pulley size is known, you can use the output curves given in section 10.4 to look up the charge current at idle speed. Multiplying the engine idle speed with the pulley ratio will give you the alternator speed at idle:  $800 \times 2.9 = 2327\text{rpm}$ . From the performance curve of the Alpha Compact 28/110, we read approximately 60A of output.

To calculate the engine speed where the alternator reaches full output, simply divide the nominal alternator speed by the pulley ratio. In this example, the alternator will reach its full capacity at engine speed:  $6000 / 2.9 = 2060\text{rpm}$ .

**Note:** No rights can be derived from this example.

#### 4.6.4 Pulley alignment

For different pulleys, the distance between the inside of the mounting foot to the first rib of the drive belt can be different. Choose an optimal distance as to minimize the pulley offset.

**Note:** Depending on the mounting method, alternative adjustments to the offset may be possible such as adding spacers between the bracket and the alternator mounting foot

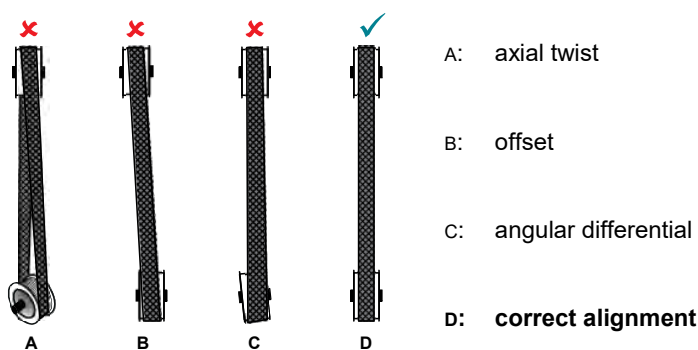


Figure 3: Pulley alignment errors



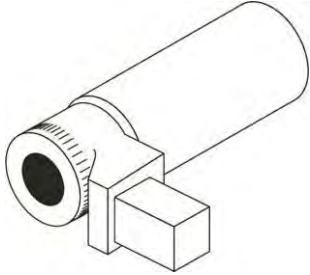
## 4.7 Pulley installation

Special tools are needed to mount a pulley. These tools are not delivered by Mastervolt. The following tools are manufactured by MAN Trucks and can be obtained from a local vendor or ordered online.



### CAUTION:

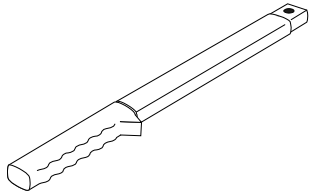
Damage as a result of the use of incorrect tools may result in loss of warranty.



#### ADJUSTING WRENCH SW22 (Y1)

To remove/install multigroove pulley, in combination with handle (Y2) and TORX screwdriver insert (X2) and torque wrench (X3).

[22mm deep socket with external drive; e.g. MAN 80.99603-6029]



#### HANDLE 14X18X630 (Y2)

To remove/install standard multigroove pulley, in combination with adjusting wrench (Y1)

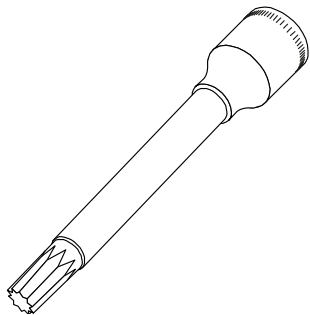
[MAN 08.06460-0002]



#### Adapter (X1)

To remove/install clutch pulley, in combination with TORX screwdriver insert (X2) and torque wrench (X3).

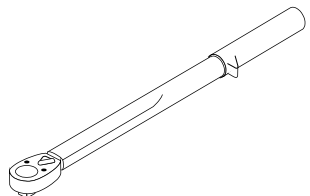
[Clutch pulley removal tool, spline 33 teeth, outer diameter 19,6mm, 22HEX drive; e.g. MAN 80.99603-0423]



#### TORX SCREWDRIVER INSERT (X2)

To remove/install standard or clutch pulley, in combination with adapter (X1) and torque wrench (X3).

[XZN M10 x 102mm/140mm, 1/2"; e.g. MAN 80.99603-0318 or Stahlwille 03261410]



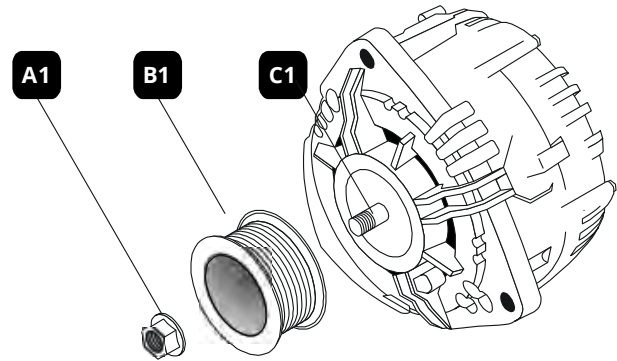
#### TORQUE WRENCH 20-100Nm (X3)

To remove/install standard or clutch pulley, in combination with adapter (X1) or (Y1) and TORX screwdriver insert (X2).

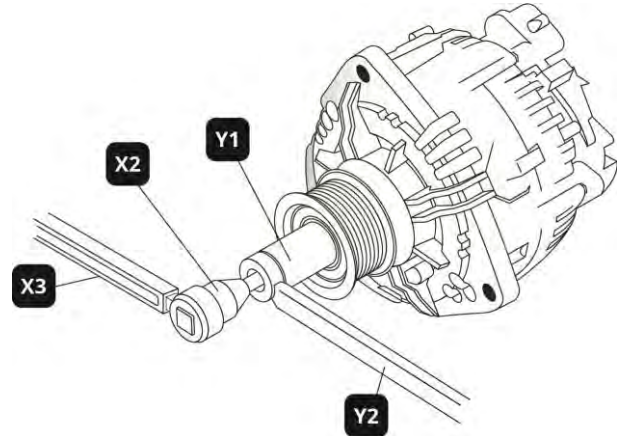
[Torque wrench 20-100Nm 1/2"; e.g. MAN 08.06450-0002]

#### 4.7.1 Standard pulley

1. Slide the multigroove pulley (B1) onto the alternator shaft (C1).
2. Thinly apply retaining compound (LOCTITE® 648) on the thread and contact surface of the new lock nut (A1).
3. Mount the new lock nut.

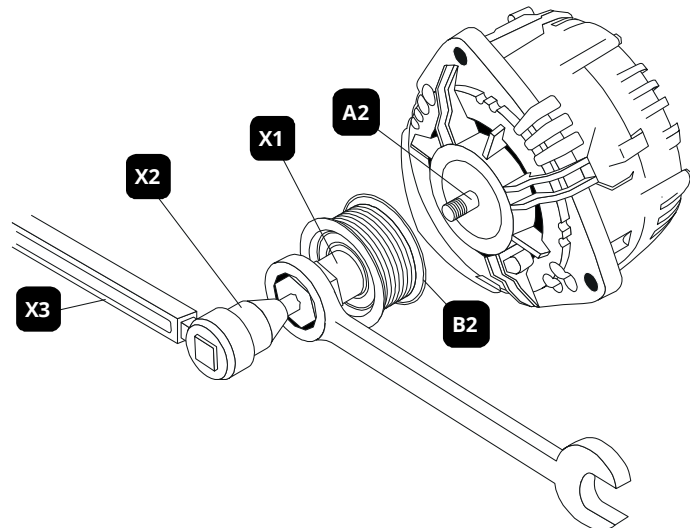


4. Fit the adjusting wrench (Y1) with handle (Y2) on the lock nut of the multigroove pulley.
5. Place the torque wrench (X3) and torx insert (X2) in the alternator shaft.
6. Hold the torque wrench (X3) and handle (Y2) and tighten the lock nut (anti-clockwise) to a **torque of 80 Nm**.

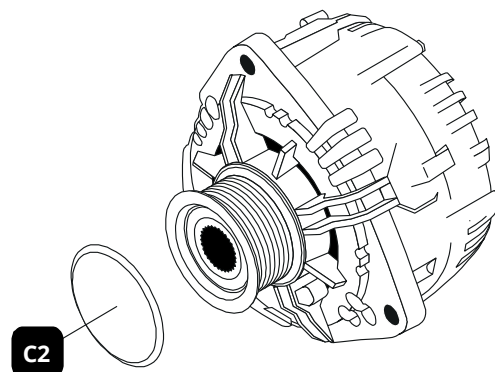


#### 4.7.2 Clutch pulley

1. Thinly apply threadlocker compound (LOCTITE® 270) on the alternator shaft (A2).
2. Place the adapter (X1) on the clutch pulley (B2) and slide onto the alternator shaft (A2).
3. Insert the torx insert (X2) into clutch pulley (B2).
4. Hold the adapter (X1) and use the torque wrench (X3) and torx insert (X2) to tighten the clutch pulley (B2) to a **torque of 85 Nm**.



5. Remove the special tools.
6. Add a protection cover (C2).



## 5 MECHANICAL INSTALLATION

### 5.1 Preparations

Turn off all switches and electrical loads. Disconnect the battery. It is advised to make pictures of the current situation, showing how the belt is routed around the pulleys.

### 5.2 Prepare mounting location

#### 5.2.1 Main alternator upgrade

1. Remove the drive belt. Loosen the alternator bolts and tilt it forward to create slack in the belt. If there is an auto-tensioner pulley, use a socket wrench to loosen it. Now you can remove the belt from the pulleys.
2. Remove the old alternator.
3. Clean and check the condition of mechanical parts and mounting points. Carefully check the belt and tensioner (if applicable) for signs of wear. Replace both if necessary.

#### 5.2.2 Secondary alternator install

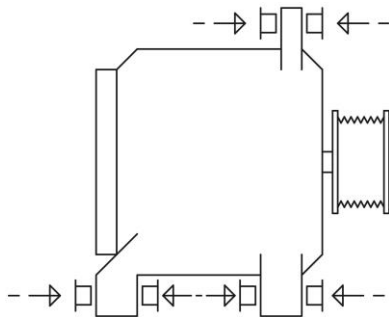
Remove the main drive belt according to section 5.2.1. Attach the mounting bracket to the engine. Install other parts of the alternator mounting kit, such as idler pulleys, double pulleys, belt tension adjuster according to the instructions of the manufacturer.

### 5.3 Alternator mounting

The mounting points of the Alpha Compact depend on the model:

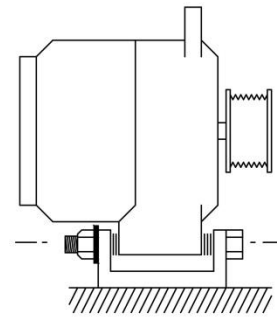
- **Foot mount:** Alpha Compact 14/120 | Alpha Compact 28/110 | Alpha Compact 28/150
- **Pad mount:** Alpha Compact 14/200
- **Saddle mount:** Alpha Compact 28/80 VP | Alpha Compact 28/110 VP | Alpha Compact 28/150 VP

Saddle mount is also known as *dual foot mount*. Pad mount is also known as *direct mount*.



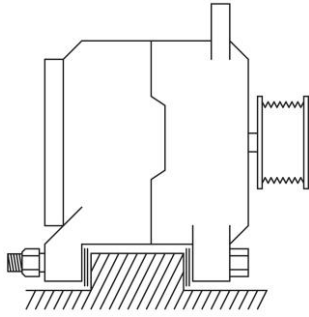
**Figure 4: Inserting isolation bushings**

If isolated mounting is required, insert isolating bushings on either side of each mounting hole. Slide the cable lug of the ground cable (discussed in section 6.3) between one of the isolating bushing and the alternator. Cut the bushings to size. Example: for an alternator model with 3 mounting positions, insert 6 bushings.



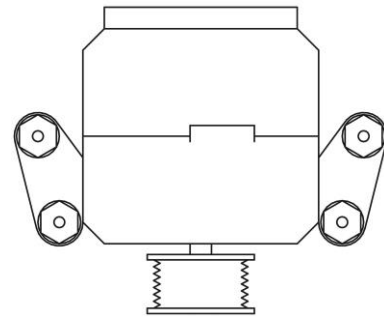
**Figure 5: Alternator mounting – foot mount**

Position the alternator mounting foot between the two ears of the mounting bracket and slide in the alternator mounting bolt. Check for backlash. Align the pulley with the crank shaft pulley and fill up any empty space on either side of the mounting foot with shims. Loosely attach the alternator, adding a spring washer and locking nut to the other end of the bolt.

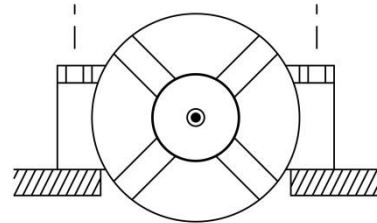


**Figure 6: Alternator mounting – saddle mount**

Position the alternator mounting ears over the mounting foot and slide in the alternator mounting bolt. Check for backlash. Align the pulley with the crank shaft pulley and fill any empty space on either side of the mounting foot with shims. Loosely attach the alternator, adding a spring washer and locking nut to the other end of the bolt.



**Figure 7. Alternator mounting – pad mount, front view**



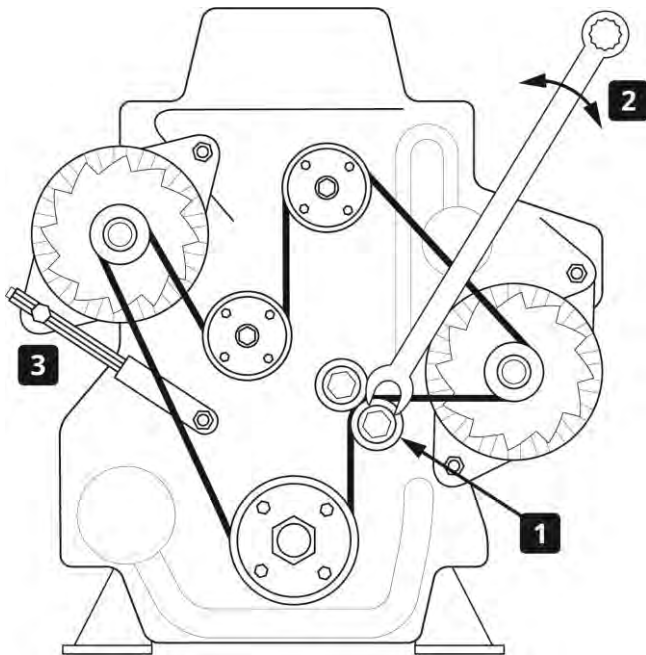
**Figure 8. Alternator mounting – pad mount, top view**

Slide the alternator into the correct position. Apply a thin layer of threadlocking compound (LOCTITE® 270) on the alternator mounting bolts and tighten the bolts.

## 5.4 Drive belt re-installation

### 5.4.1 With auto-tensioner pulley

1. Run the drive belt through the pulleys, skipping the auto-tensioner (1).
2. Loosen the auto-tensioner using a wrench (2).
3. With the belt around all of the other pulleys, slide it over the auto-tensioner (1) while still holding pressure on the wrench.
4. Once the belt is in place, slowly reduce the pressure on the wrench, allowing the tensioner pulley to tighten the belt.



**Figure 9: Re-installation with auto-tensioner**

### 5.4.2 No auto-tensioner pulley

1. Run the drive belt through the pulleys, skipping the alternator.
2. Tip the alternator forward and loosely fix the adjustment ear to the adjustment arm (3).
3. Now slide the belt over the alternator pulley.
4. Tighten the belt by pulling the alternator backward, applying force to the front of the alternator housing only.
5. Set the belt tension per manufacturer's recommendations. Use a belt tension gauge to verify the tension.

### 5.4.3 Final check

Double check the belt alignment. Firmly tighten all alternator mounting bolts.

## 6 ELECTRICAL INSTALLATION



### WARNING

Installation work should be carried out by qualified personnel only.



### CAUTION! Risk of equipment damage

Short circuiting or reversing polarity may lead to serious damage to the batteries, the alternator, the Alpha Pro regulator, the cabling and/or the terminal connections. Fuses cannot prevent damage caused by reversed polarity. Damage caused by reverse polarity is not covered by the warranty.

Interrupting current from a running alternator may lead to a significant voltage surge, with damage to the alternator and/or connected equipment and loss of warranty as a result. Carefully follow the instructions in this chapter regarding wiring, fuse size and fuse position.



### CAUTION! Risk of fire

Too-thin cables and/or loose connections can cause dangerous overheating of the cables and/or terminals. Tighten all connections well, in order to limit transition resistance as far as possible. Use cables of the correct size. Refer to technical specifications (section 10.2) for recommended wire sizes.

### 6.1 Precautions

Make sure that everything is switched off:

- remove the engine ignition key;
- disconnect all batteries or remove the DC fuse(s);
- make sure that third parties cannot reverse the measures taken.

### 6.2 Fuse

The alternator is connected to the battery via an alternator fuse, located as close as possible to the battery. Refer to section 10.2 Technical specifications, on page 19, for more information.

### 6.3 Wiring

Refer to Figure 10 on page 14.

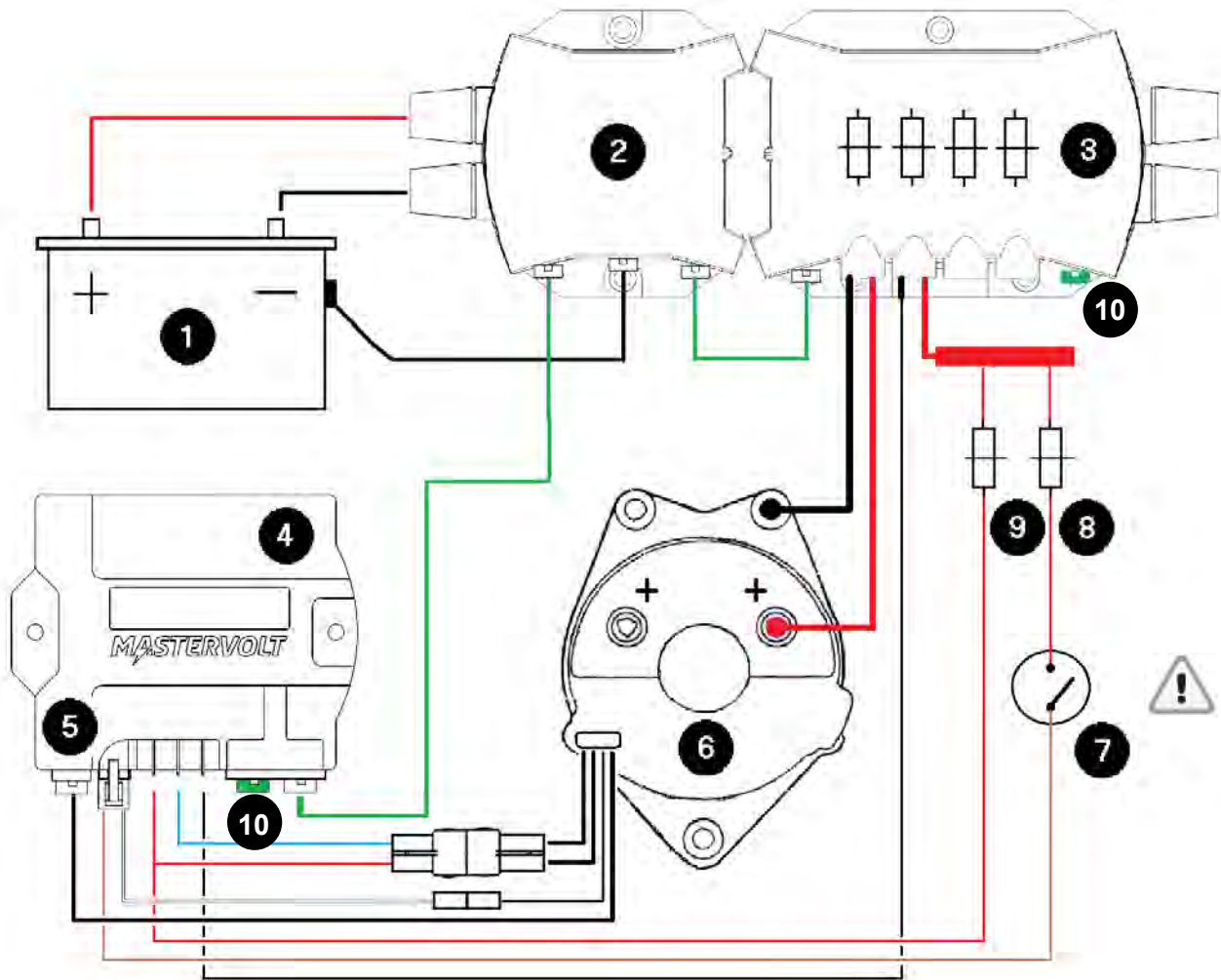
#### Notes:

- Whether the alternator is mounted in an isolated or a non-isolated way, it is recommended to always route a ground conductor from one of the alternator mounting points to electrical ground.
- The current rating of the positive and negative alternator wiring must be higher than the fuse size.
- Use the supplied cable assembly for connection of the Alpha Pro regulator.
- The alternator temperature sensor must be connected to the temperature input of Alpha Pro. In case lead acid batteries are used, it is advised to install a MasterShunt with battery temperature sensor and make a MasterBus connection to the Alpha Pro to use automatic temperature compensation.



### CAUTION:

Point 7 in Figure 10 should NOT be connected to engine ignition. Refer to the Alpha Pro manual, which explains how to obtain a proper “engine run” signal. **Failure to do so may lead to overcharging of the batteries and / or overheating of the alternator field winding, which is not covered by warranty.**



1 VRLA battery

2 MasterShunt

3 DC distribution with dedicated alternator fuse

4 Alpha Pro III regulator

5 Alternator temperature sensor

6 Alpha Compact alternator

7 Engine Run Contact - refer to Alpha Pro manual

8 Fuse - refer to Alpha Pro manual

9 Fuse (included in Alpha Pro wiring loom)

10 MasterBus Terminator

Figure 10: Wiring diagram with lead acid battery

## 7 COMMISSIONING

### 7.1 Preparations

1. Wear safety glasses and remove loose fitting clothing and jewelry.
2. Clear the area around moving parts. Remove loose wires and tools.
3. Double check all electrical connections.
4. Reconnect the battery.
5. Switch on the DC power.

### 7.2 Regulator configuration

Refer to the Alpha Pro regulator manual for details on MasterBus configuration.

Leave the selector switch of Alpha Pro on its default setting: "MasterBus".

**Note:** The Alpha Pro will be disabled until it is configured and locked via the MasterBus menu.

#### 7.2.1 Set alternator type

On the Alpha Pro MasterBus configuration page:

1. Go to **Alternator type**.
2. Set **alternator type** to the correct [Alpha Compact XX/YYYY] type.
3. If your type is not in the list, select [user defined].
  - Set the **system voltage** for your alternator.
    - Alpha Compact 14/YYYY models: [12V]
    - Alpha Compact 28/YYYY models: [24V]
  - Set **# of pole pairs** to [6]
4. Set the **temperature sensor** to [Alternator].
5. Set **Start reducing** to [100°C].
6. Set **Stop charging** to [120°C].
7. Double check the settings and keep a record of them in this manual.

#### 7.2.2 Other settings

Refer to the Alpha Pro manual for other settings and how to lock the Alpha Pro regulator.

### 7.3 First operation

1. To bridge the engine run contact (7), connect a jump wire.
2. Measure and record the battery voltage at idle.
3. Turn on the ignition switch, without starting the engine.
  - The three LEDs on the Alpha Pro should blink to indicate startup mode.
4. Check whether the alternator field coil is energized, by touching the shaft of the alternator with a screwdriver. You should notice a strong magnetic pull.
5. Start the engine. Be aware of moving parts. Check for abnormal noise or vibration.
  - After 10 seconds, the yellow (bulk) LED will illuminate, indicating that the charge cycle begins.
6. Measure and record the battery voltage. It should be higher than the idle voltage, indicating that the alternator is charging.
7. Run the engine at cruising speed for 15 minutes, switching on loads to apply maximum load to the alternator.
8. Stop the engine and check the belt tension. Adjust if necessary.
9. Remove the jump wire.

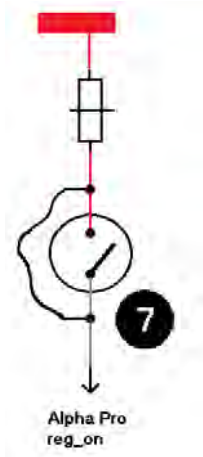


Figure 11: jump wire

### 7.4 Normal operation

The Alpha Compact alternator and the Alpha Pro regulator will switch on automatically. There is no need for adjustment or operation. If installed correctly, the Alpha alternator and the Alpha Pro regulator will switch off as well when the engine stops.

## 8 MAINTENANCE

Alternator installations are pretty much maintenance free except for changing the belt periodically and keeping correct belt tension. For better cooling it helps to keep the alternator clean. A periodic test of its performance will help to spot problems in advance.

### 8.1 Mounting points

Check the mounting of the alternator after the first 50 running hours. Then every 150 running hours or at least every year, whichever comes first. Make sure that the alternator is securely mounted to its applicable brackets. The brackets, in turn, need to be bolted securely to the engine. Poor or loose mountings may lead to damaging vibration as well as reduced belt drive performance.

### 8.2 Cleaning



**CAUTION:**

Use only non-aggressive detergents.

The cleaning interval of the alternator strongly depends on environmental conditions but should be maximum six months. Prevent build-up of dirt, grease or dust. If you notice significant build-up of black dust on your alternator and surrounding engine area, check belt tension.

Air flow passages must also be clear so that air can easily pass through the unit. The alternator's bearings are greased for life and cannot be degreased.

### 8.3 Check tension and condition of the drive belt

An under-tensioned belt will slip on the pulley, fail to turn the alternator's rotor and as a result of the friction, overheat the alternator. An over-tensioned belt causes reduced belt life. The tension of new belts must be checked after the first 50 running hours; then every 150 running hours or at least every year.

Before adjusting the belt tension, inspect it for glazing, cracks, or dryness. A worn or damaged belt should be replaced, including the tensioner (if applicable). If the belt is in satisfactory condition, check the belt tension with cricket belt tension gauge. Refer to the manufacturer's specifications for proper belt tension.

If you replace a worn or damaged drive belt, the new belt should be checked for proper tension as well. A new drive belt loses up to 60% of its tension during the first few hours of operation. If a new belt has been installed, run the engine with full load connected to the alternator for approximately 15 minutes. Then check the belt tension again and adjust it if necessary.



## 9 TROUBLESHOOTING

### 9.1 Trouble shooting hints

- Check if 12-14V is present at alternator output
- Check if 12-14V is available at field current input. When field current is present, hold a Ferro-metallic object near the shaft of the alternator. The field coil functions correctly if a strong magnetic pull is observed.

### 9.2 Fault finding table

Problem	Possible cause	Action
Battery loses charge or Insufficient charge output	Defective battery	Check battery, replace if necessary.
	Slipping alternator drive belt	Check belt condition and tension.
	Battery terminals loose or corroded	Clean, grease and tighten battery terminals.
	Alternator internal fault	Test and repair if necessary.
	Regulator fault	Refer to regulator manual.
	Engine run signal contact not working	Jump wire engine run signal contact. Repair if necessary.
	Bad electric connection in main charging circuit	Check cables for damage. Check ground wire,
	Short circuit component causing battery drain even when switches are off	Measure battery output current drain and check system.
	Blown alternator fuse	Verify fuse value. Replace with fuse according to specifications (section 10.2)
	Alternator temperature sensor not correctly configured	Check MasterBus configuration.
Charge current higher or lower than expected	Charge current can be up to 20% higher when cold. Charge current can be up to 15% lower when hot.	Not a problem.
Charge voltage too high / low	Wrong battery sense voltage	Check battery voltage sense wiring.
Noise	Belt misalignment.	Make sure the pulleys are aligned.
	Anti-clockwise sense of rotation	Check the sense of rotation.
	Belt tension too high	Check belt tension.
	Pulley mounting	Fasten pulley, using special tools.
	Worn or misaligned tensioner pulley	Check tensioner pulley.
Pivot bushing worn down	Belt misalignment.	Make sure the pulleys are aligned.
Alternator is getting hot while engine is <b>NOT</b> running	Rotor field windings are excited while engine is not running. Regulator is still on (bulk/abs/float led is on)	Switch off DC immediately to avoid field winding damage due to overheating. Check engine run contact for correct operation. Check wiring between battery and [reg on] terminal.
Alternator is getting hot while engine <b>IS</b> running	A loose, under-tensioned belt	Check the tension of the belt.
	Anti-clockwise sense of rotation	Check correct sense of rotation.

## 10 TECHNICAL DATA

### 10.1 General specifications

Alpha Compact	14/120	14/200	28/110	28/150
Mounting*	Foot mount	Pad mount	Foot mount	Foot mount
Pulley included	N/A	# 48420110	N/A	N/A
Weight	6.5 kg / 14.3 lb	7.5 kg / 16.5 lb	7.4 kg / 16.3 lb	7.9 kg / 17.4 lb
Charge regulation	Alpha Pro III charge regulator (order separately)			
Isolated operation	Yes, with optional isolation bushings			
Rotational direction	clockwise (viewed from pulley side)			
Galvanic isolation	non-isolated			
Cooling	integrated dual fan			

Alpha Compact	28/80VP	28/110VP	28/150VP
Mounting*	Saddle mount	Saddle mount	Saddle mount
Pulley included	# 48420170	# 48420170	# 48420170
Weight	6.9 kg / 15.2 lb	7.4 kg / 16.3 lb	7.9 kg / 17.4 lb
Charge regulation	Alpha Pro III charge regulator (order separately)		
Isolated operation	Yes, with optional isolation bushings		
Rotational direction	clockwise (viewed from pulley side)		
Galvanic isolation	non-isolated		
Cooling	integrated dual fan		

(\*) Refer to section 5.3 on page 11.

## 10.2 Technical specifications

Alpha Compact model	14/120	14/200	28/110	28/150
System voltage	12 V	12 V	24 V	24 V
Battery capacity	240 – 1200 Ah	400 – 2000 Ah	220 – 1100 Ah	300 – 1500 Ah
Nominal current* @ 6000rpm	120 A	200 A	110 A	150 A
Charge current @1800rpm	70 A	106 A	41 A	28 A
Recommended DC fuse	175 A	300 A	160 A or 175 A	225 A
Recommended DC wire size (up to 3m)	50 mm <sup>2</sup> / AWG0	70 mm <sup>2</sup> / AWG3 0	35 mm <sup>2</sup> / AWG2	50 mm <sup>2</sup> / AWG0
Recommended wire size (3 to 5m)	70 mm <sup>2</sup> / AWG2 0	95 mm <sup>2</sup> / AWG4 0	50 mm <sup>2</sup> / AWG0	70 mm <sup>2</sup> / AWG2 0
Cut-in speed	1300rpm	1350rpm	1400rpm	1700rpm
Max. rotational speed	20.000rpm	20.000rpm	15.000rpm	16.000rpm
Power Take Off (kW/hp)	3.4/4.5	5.6/7.6	6.2/8.3	8.4/11.4
Max. operating temperature	125 °C / 250 °F			
Connections	positive output stud = 2x M8; W (rpm) signal connection = isolated fast-on; field current connection = Mastervolt plug			
Temperature sensor	integrated, RJ12 connector			

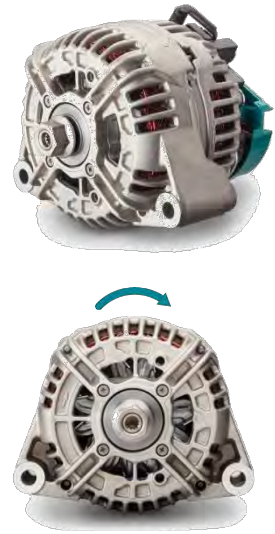
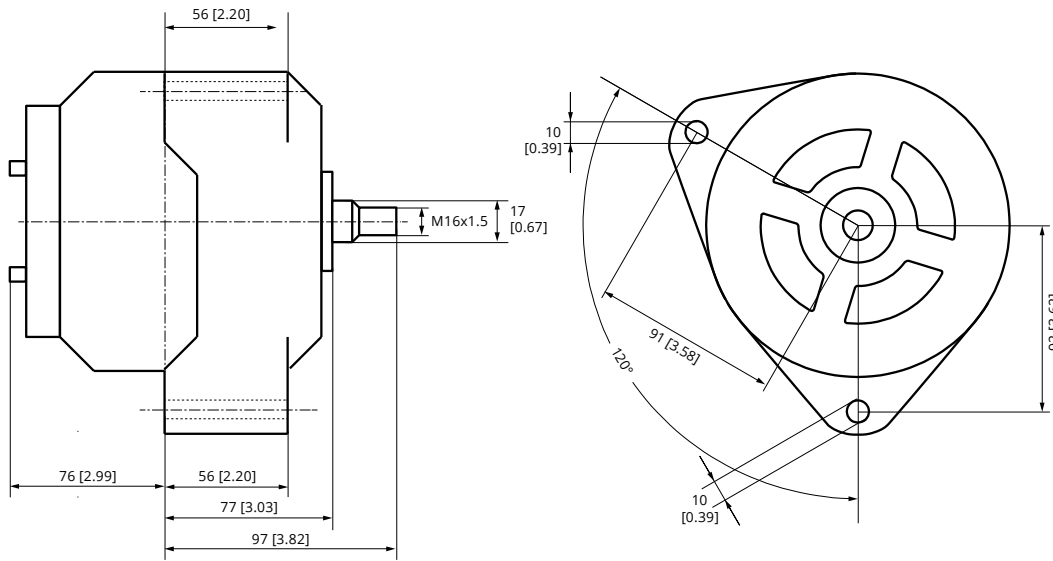
Alpha Compact model	28/80VP	28/110VP	28/150VP
System voltage	24 V	24 V	24 V
Battery capacity	160 – 800 Ah	220 – 1100 Ah	300 – 1500 Ah
Nominal current* @ 6000rpm	85 A	110 A	150 A
Charge current @1800rpm	45 A	40 A	30 A
Recommended DC fuse	125 A	160 A or 175 A	225 A
Recommended DC wire size (up to 3m)	35 mm <sup>2</sup> / AWG2	35 mm <sup>2</sup> / AWG2	50 mm <sup>2</sup> / AWG0
Recommended wire size (3 to 5m)	50 mm <sup>2</sup> / AWG0	50 mm <sup>2</sup> / AWG0	70 mm <sup>2</sup> / AWG2 0
Cut-in speed	1400rpm	1400rpm	1700rpm
Max. rotational speed	15.000rpm	15.000rpm	16.000rpm
Power Take Off (kW/hp)	4.8/6.4	6.2/8.3	8.4/11.4
Max. operating temperature	120 °C / 250 °F		
Connections	positive output stud = 2x M8; W (rpm) signal connection = isolated fast-on; field current connection = Mastervolt plug		
Temperature sensor	integrated, RJ12 connector		

\*) Nominal charge current is specified at 6000rpm, 25°C ambient temperature and a “warm” alternator. When the alternator is cold, charge currents can be up to 20% higher. At high ambient temperature (80°C), charge currents can be up to 15% lower.

10.3 Mechanical specifications – Alternators

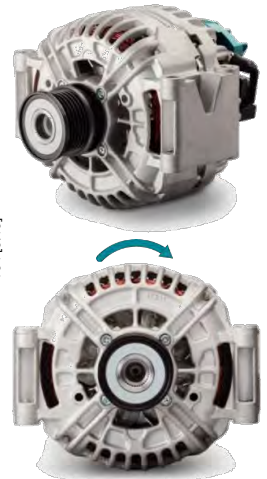
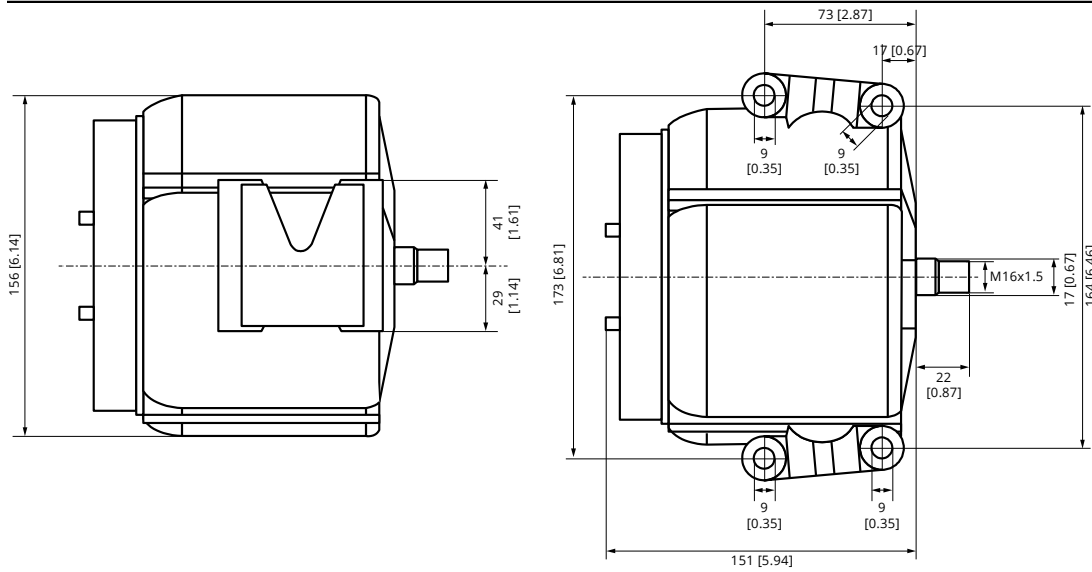
Alpha Compact 14/120 (dimensions in mm [inch])

Code 46214120



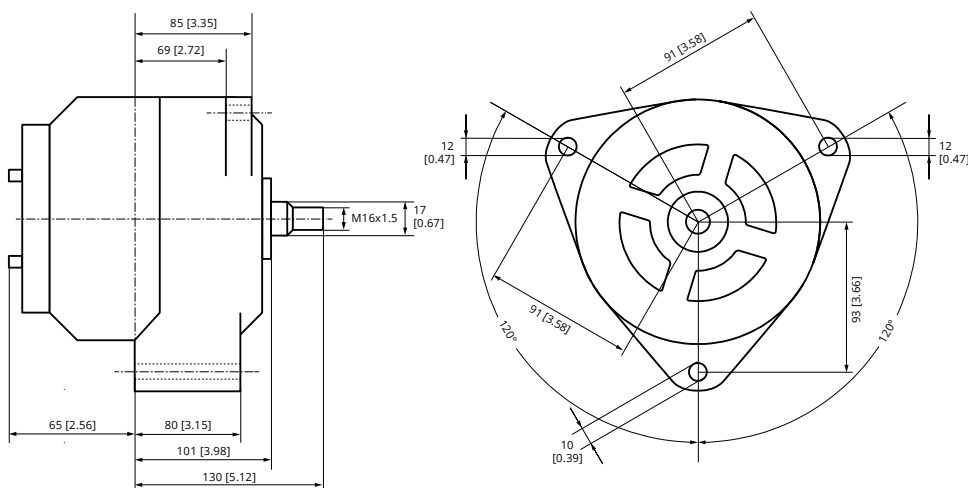
Alpha Compact 14/200 (dimensions in mm [inch])

Code 46214200



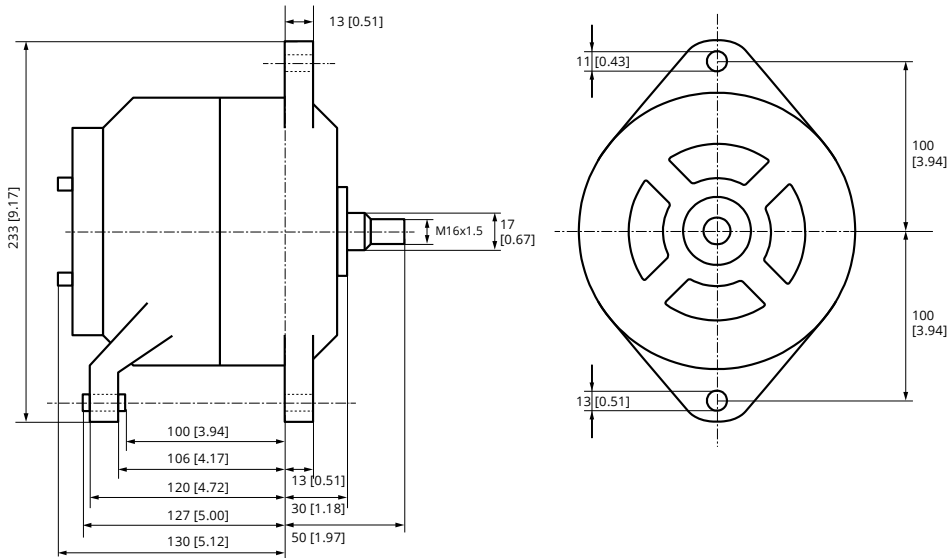
Alpha Compact 28/110 & Alpha Compact 28/150 (dimensions in mm [inch])

Code 46228110 & 46228150



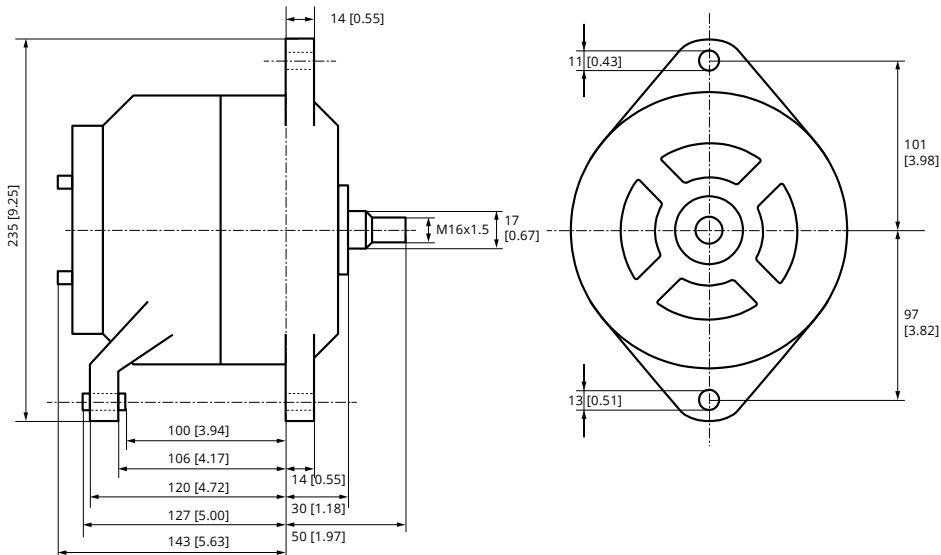
**Alpha Compact 28/80 VP & 28/110 VP (dimensions in mm [inch] )**

Code 46228080 & 46228110

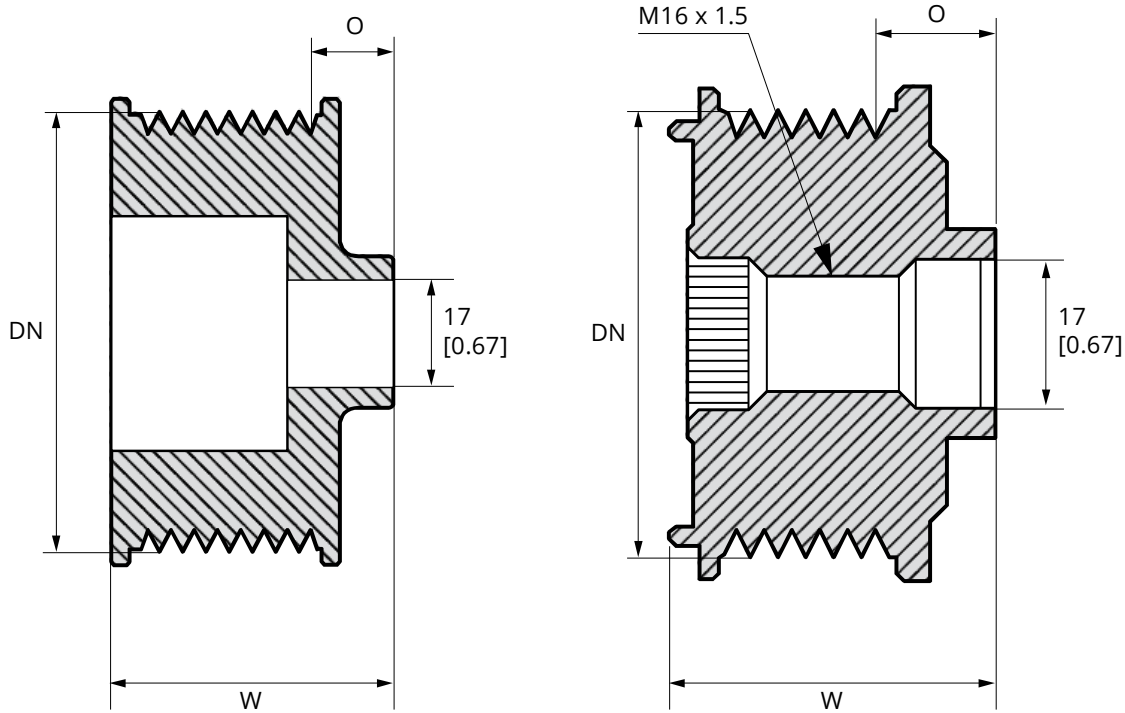


**Alpha Compact 28/150 VP (dimensions in mm [inch] )**

Code 46228150



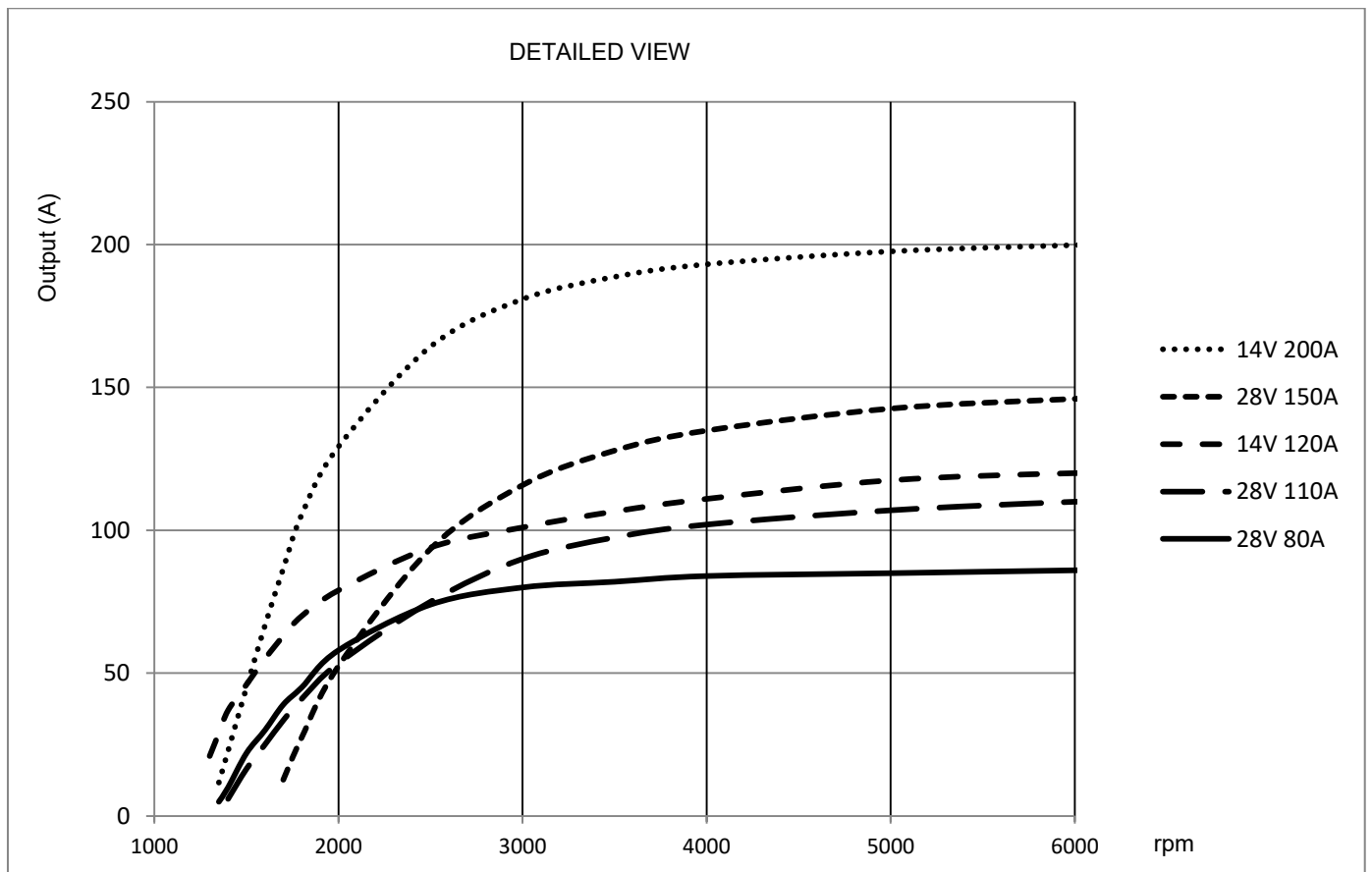
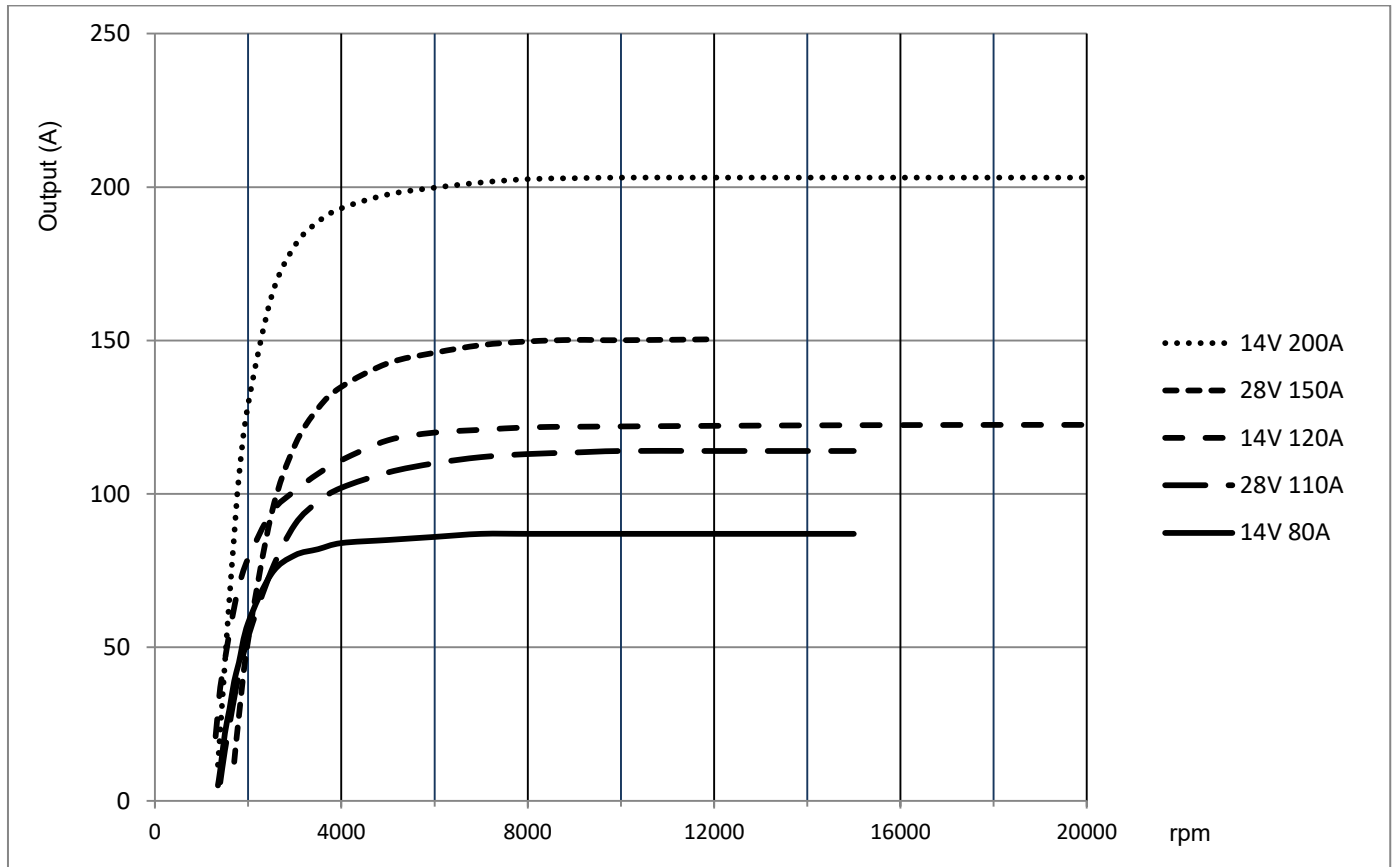
## 10.4 Mechanical specifications – Pulleys



Product code	Type	Grooves	Offset (O)	Width (W)	Diameter (DN)
48420100	Clutch	8	3.9 [0.15]	37.4 [1.47]	57.4 [2.26]
48420110	Clutch	6	15.2 [0.60]	40.3 [1.59]	49.8 [1.96]
48420120	Clutch	6	14.5 [0.57]	42.8 [1.69]	56.2 [2.21]
48420130	Clutch	6	9.9 [0.39]	36.1 [1.42]	55.0 [2.17]
48420140	Clutch	8	4.5 [0.18]	38.9 [1.53]	56.0 [2.20]
48420150	Clutch	8	19.4 [0.76]	49.3 [1.94]	50.0 [1.97]
48420160	Standard	8	5.5 [0.22]	34.6 [1.36]	66.1 [2.60]
48420170	Standard	8	10.0 [0.39]	39.4 [1.55]	48.1 [1.89]
48420180	Standard	2 x 8	5.5 [0.22]	68.7 [2.70]	66.1 [2.60]

*Dimensions in mm [inch]*

## 10.5 Output curves



Copyright © 2019 Mastervolt. All rights reserved.  
Reproduction, transfer, distribution or storage of part or all of the contents in this document in any form without the prior written permission of Mastervolt is prohibited.

**MASTERVOLT**

Mastervolt B.V.  
Snijdersbergweg 93  
1105 AN Amsterdam  
The Netherlands

Tel.: +31-20-3422100  
Email: [info@mastervolt.com](mailto:info@mastervolt.com)  
Web: [www.mastervolt.com](http://www.mastervolt.com)